



Where Materials Flow by Design

Lean Material Flow Solutions

ProFlow™ Series

Flat Deck Carts

1350 Rockefeller Rd., Wickliffe, OH 44092, PH 440.943.4111, info@KtecInc.com, www.KtecInc.com

FLAT DECK CARTS

K-Tec flat deck carts deliver flexibility and top quality to complement **lean material flow** programs. Features include:

- Auto-Lock Deck w/Mechanical Linkage
- Auto-Release Floor Lock
- Rotational Deck Sealed Precision Bearings
- Choice of Two (2) Popular Deck Sizes
- Low Push/Pull Force 4 or 6 Wheel Systems
- Built-In Pocket For Pneumatic or Hydraulic Lifts

INDUSTRY LEADING DESIGN

Carts meet standard ergonomic limits for manual push/pull forces with heavy payloads and standup to tough loading conditions. FEA (finite element analysis) puts stiffness and weight where needed to produce carts as

light and rugged as possible. Innovations such as MPP™ (modified pivot point) caster steering allow significant improvements in tracking and turning resulting in low frame height and manual pushing capability. Numerous “attention to detail” features help K-Tec meet rigorous **safety**, reliability and durability standards. K-Tec ProFlow™ Series carts carry a **two (2) year warranty**.¹

COMMITMENT TO SUCCESS

K-Tec identifies and benchmarks relevant applications, addresses ergo/safety issues and provides on-site feasibility reviews where required. Application engineers are available by conference call or direct appointment to help walk through the early planning and front end design phase of lean material flow projects.²



Model Shown: KT2-37R on PL3000P lift



Model Shown: KT2-49R

K-Tec also designs ergo-support products such as lifts and conveyors to provide an integrated, dependable solution. A “try before you buy” **demo program** for qualified customers delivers a hands on look at a forklift free solution without wasting investment dollars.

1. See web site for warranty detail. 2. May be subject to consulting charges.

Distributed By:

Lean Material Flow Solutions

Flat Deck Carts

1350 Rockefeller Rd., Wickliffe, OH 44092, PH 440.943.4111, info@KtecInc.com, www.KtecInc.com

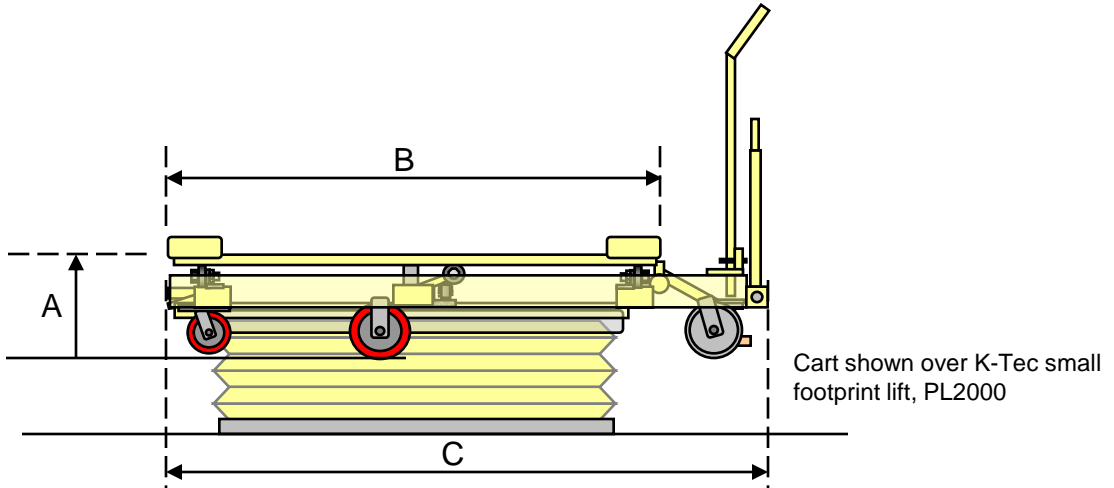

Flat Deck Carts

Model: KT2-37R

Model: KT2-37NR

Model: KT2-49R

Model: KT2-49NR

Dimensions	Model: KT2-37R	Model: KT2-37NR	Model: KT2-49R	Model: KT2-49NR
Floor to Deck Height, A	12"	10.1"	12"	10.1"
Usable Deck Size, B	37.5" x 37.5"	37.5" x 46"	49.5" x 49.5"	49.5" x 58.5"
Overall Cart Length, C	53.8"	53.5"	68.4"	65"
Overall Cart Width, D	39"	38.5"	51.3"	50.5"
Standard Features**				
4-Wheel Caster Steer w/Kingless Swivels, Hybrid Low Push/Pull Force	✓	✓		
6-Wheel Caster Steer w/Kingless Swivels, Hybrid Low Push/Pull Force (FOR RAMP USE CONSULT FACTORY)			✓	✓
Welded Steel, Industrial-Duty Perimeter Frame w/Powder Paint Finish	✓	✓	✓	✓
Built-in Lift Pocket Fits 7" x 24" x 38" Pneumatic or Hydraulic Lifts	✓	✓	✓	✓
Rotational Upper Deck w/Soft Detents at 90° and Auto-Lock (towbar activated)	✓		✓	
Precision Sealed Wheel and Swivel (rotational deck if applicable) Bearings	✓	✓	✓	✓
Operator No-Bend Heavy-Duty Auto-Hitch and Self Stowing, Reinforced Towbar	✓	✓	✓	✓
Heavy Duty Floor Lock w/Auto-Release (towbar activated)	✓	✓	✓	✓
MPP™ (modified pivot point) Caster Steering (FOR RAMP USE CONSULT FACTORY)			✓	✓
Cart Tare Weight	354 lbs.	273 lbs.	554 lbs.	385lbs.
Deck Load Capacity	2000 lbs.	2000 lbs.	2000 lbs.	2000 lbs.
Rated Load Capacity (to meet ergo guidelines w/standard wheels)	1500 lbs.	1500 lbs.	1500 lbs.	1500 lbs.

Application photos, technical specifications and CAD drawings can be found on the web site at www.KtecInc.com